

# HAMBURGATRICE - POLPETTATRICE

## HAMBURGER - MEATBALL FORMING MACHINE



## MACCHINA FORMATRICE DI HAMBURGER, CON POLPETTATRICE INTEGRATA

- Vetrina, Vasca e coperchio in acciaio Inox
- Struttura in acciaio Inox
- Macchina su carrello integrato dotata di ruote autofrenanti
- Funzione di stratificatore (per Hamburger)
  - Altezza utile di stratificazione: 80 mm
- Pulizia filo automatico di serie
- Gruppo pale a smontaggio rapido
- Dotazione standard: Variatori di velocità (per Hamburger e Polpetta)
  - Dispositivo interfogliatore - Oliatore (per polpetta)

## HAMBURGER FORMING MACHINE WITH BUILT-IN MEATBALL FORMING MACHINE

- Stainless steel hopper, frontal door and lid
- Stainless steel structure
- Machine on trolley with self-braking wheels
- Stacking function (for hamburgers) - Useful stacking height: 80 mm
- Automatic Scraper Device
- Shaft assembly easily removable and changeable
- Standard equipment: Speed variators (for Hamburgers and Meatballs)
  - Paper Interleaver Device - Oil feeder (for meatballs)

## RECONSTITUEUSE POUR HAMBURGER, AVEC DISPOSITIF POUR BOULETTES INTÉGRÉ

- Vitrine, tremie et couvercle en acier inox
- Structure en acier inox
- Machine sur chariot intégré doté de roues auto-freinées
- Fonction de stratification (pour hamburgers)
  - hauteur utile de stratification: 80 mm
- Nettoyage automatique du fil racloir
- Groupe pales à démontage rapide
- Equipement standard: Variateur de vitesse pour hamburgers et boulettes
  - distributeur automatique de papier - burette d'huile (pour boulettes)

## HAMBURGER-MASCHINE MIT INTEGRIERTER FLEISCHKLOSS-MASCHINE

- Vitrine, Fülltrichter, und Deckel aus Inox-Stahl
- Aufbau aus Inox-Stahl
- Maschine auf integriertem Wagen mit selbstbremsenden Rädern
- Schichtfunktion (für Hamburger)- nutzbare Höhe für schichten: 80 mm
- Automatische Reinigung des Drahtabstreifers
- Mischschaufe mit Schnellausbauvorrichtung
- Standardausrüstung: Drehzahlregelungen für Hamburgers und Fleischklöße
  - Rennblatteinleger - Integrierter Öler (für Fleischklöße)

## MÁQUINA DE HAMBURGUESAS CON DISPOSITIVO PARA ALBÓNDIGAS INTEGRADO

- Puerta frontal, cuba y tapa de acero inoxidable
- Estructura de acero inoxidable
- Máquina portante, dotada de ruedas autofrenantes
- Función de estratificador (para hamburguesas) - Altura útil de apilado: 80 mm
- Limpieza automática del hilo separador
- Ensamblaje palas de desmontaje rápido
- De serie con la máquina: variador de velocidad (para hamburguesas y albóndigas) - Dispositivo colocador de papel - Dosificador de aceite (para albóndigas)

La versione della macchina destinata al mercato nord americano è certificata ETL Sanitation, e cETL Safety per il mercato canadese.

The version of the machine destined for the North American market is ETL Sanitation certified, as well as cETL Safety certified for the Canadian market.

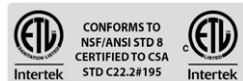

## CARATTERISTICHE TECNICHE - TECHNICAL SPECIFICATIONS - TECHNISCHE DATEN - CARACTÉRISTIQUES - ESPECIFICACIONES

		C/E HF
Alimentazione - Power supply - Alimentation - Versorgung - Alimentación	V./Hz	230/1/50
Potenza assorbita - Power input - Puissance absorbée - Aufgenommene Leistung - Potencia absorbida	kW (HP)	0,9 (1,2)
Capacità vasca - Hopper capacity - Capacité tremie - Fassungsvermögen Fülltrichter - Capacidad cuba	l	40
HAMBURGERS/PATTIES Produzione max. - Max. output - Production max.- Produktion max. - Máx producción (*)	hamburgers/h	~ 3000
POLPETTE/ MEATBALLS Produzione max. - Max. output - Production max.- Produktion max. - Máx producción (**)	meatballs/h (**)	~ 6000
Peso netto - Net weight - Poids net - Nettogewicht - Peso neto	kg	160

(\*) Approssimativo, a seconda dell'impasto - Approximate, depending on the mixture - Approximatif, selon le type de pâte - Ungefähr, je nach Teig - Aproximativo, según la mezcla

(\*\*) Considerando formato doppio - Considering double size - Pour un format double - Unter Berücksichtigung des Doppelformats - Considerando el formato doble

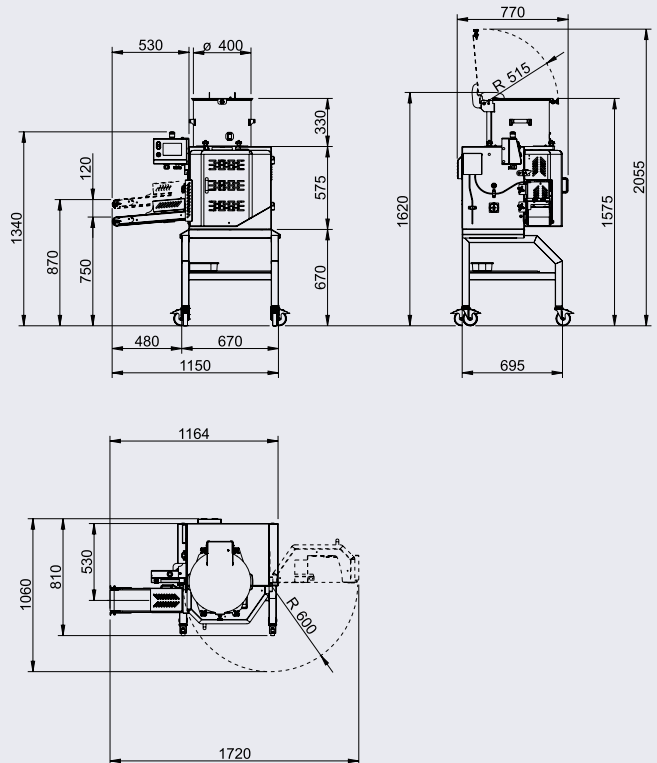

HAMBURGER PATTY	DIMENSIONI DIMENSIONS	POLPETTE MEATBALLS	DIMENSIONI DIMENSIONS
	Max. Ø 135 mm (spessore max/ max thickness: 30 mm)		Min. Ø 25 mm Max. Ø 39 mm
	Macchina conforme alle norme CE in materia di igiene e di sicurezza.		The machine complies with CE standards in terms of hygiene and safety.